

KUNKLE SAFETY AND RELIEF PRODUCTS

MODELS 91, 218 AND 228

Cast Iron Liquid Relief Valves

Model 228

Model descriptions

Model 91: Bronze trim, with pressure-tight cap. Suitable for maximum back pressure of 60 psig¹. Variation "03" for field adjustability.

Model 218: Bronze trim, UL and FM approved for fire pump installations. Special design offers minimum set pressure of 60 psig¹. Easily adjustable with handwheel to 200 psig (175 psig with optional 125# inlet flange).

Model 228: Bronze trim, with pressure-tight cap. UL and FM approved for fire pump installations. Suitable for maximum back pressure of 60 psig¹. Supplied with handwheel.

Features

- Bolted bonnet permits easy inspection and servicing without removal from system.
- Quality cast iron body and bonnet, insert and disc are available in either bronze or Stainless Steel (SS) and lapped for optimum performance.
- Springs are steel with plating for corrosion protection.
- High lift, wing-guided disc offers high relieving capacity. Pivot between disc and spring corrects misalignment and compensates for spring side thrust.
- Each Kunkle valve is tested and inspected for pressure setting and leakage.

Technical data
Pressure and Temperature Limits²
Model 91:

5 to 400 psig;
-20° to 406°F

Models 218, 228:

60 to 200 psig;
-20° to 406°F

Furnished standard with ANSI rated B16.1 - 250# inlet flange and ANSI rated B16.1 - 125# outlet flange.

Notes:

1. Back pressure increases set pressure on a one to one basis, and reduces capacity. Back pressure in excess of 10% of set pressure is not recommended.

Applications

- Fire Pump Service, UL1478 listed and FM approved. (models 218, 228)
- Overpressure relief and protection of pumps, tanks, lines and hydraulic systems.
- Pressure regulation.

Options

- SS trim. (insert and disc) (variation 02)
- Female x Female NPT connections. (1 1/2" to 4" sizes)

- Inlet and outlet flanges per ANSI B16.1 - 125#. Limited to 175 psig maximum set pressure.
- Epoxy-coated internal body and bonnet for corrosive environments. Temperature limit 125°F [52°C].

2. For other pressure and temperature limits, consult ANSI B16 cast iron flange standards.

Parts and Materials

Model 91^{3, 6} - Non-code, Liquid Relief Valve

No.	Part Name	Materials
1	Body	Iron, A126 Class A or B
2	O-ring	BUNA-N
3	Insert	1
4	Disc	1
5	Spring Step	2
6	Spring	Steel, Aluminum Coated
7	Bonnet Gasket	Fiber and Nitrile, Klinger C-4400 or C-4401
8	Hex Head Cap Screw ³	Steel, SAE Gr. 5
9	Bonnet	Iron, A126 Class A or B
10	Cap Gasket ⁵	Fiber and Nitrile, Klinger C-4400 or C-4401
11	Compression Screw Bushing	Iron, A536 80-55-06
12	Jam Nut	4
13	Compression Screw	4
14	Cap ⁵	Iron, A126 Class A or B
15	Socket Set Screw	Steel, Commercial
16	Stem	2

Items Not Shown

Handwheel ⁵	Iron, A126 Class A or B
Handwheel Jam Nut ⁵	Steel Plated, Commercial

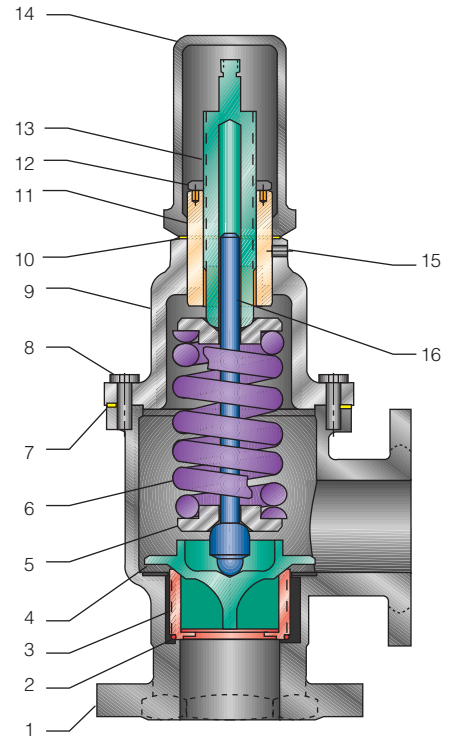

Model 91

Notes:

1. Disc (item 4) and insert (item 3) material Bronze, B-584 Alloy 84400 or B62, also available in SS, A743 Gr. CF-8, as a package option.
2. Material CS with anti-corrosion coating, commercial Gr. or Brass, B16.
3. 6 bolts required for 3" and 4" sizes, and 8 bolts required for 6" size.
4. Material Brass, B16 or Bronze, B584 casting.
5. Handwheel option available, delete cap (item 14) and gasket (item 10).
6. Inlet and outlet flanges per ANSI B16.1 250#, inlet flange standard and 125# inlet flange optional. Outlet flange 125#.

KUNKLE SAFETY AND RELIEF PRODUCTS

MODELS 91, 218 AND 228

Parts and Materials

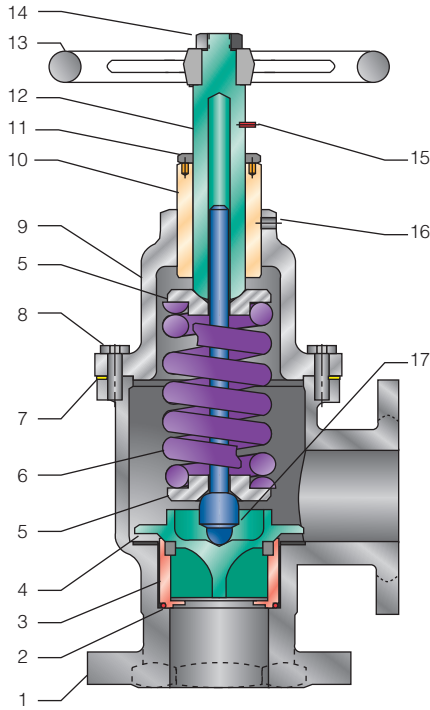

Model 218

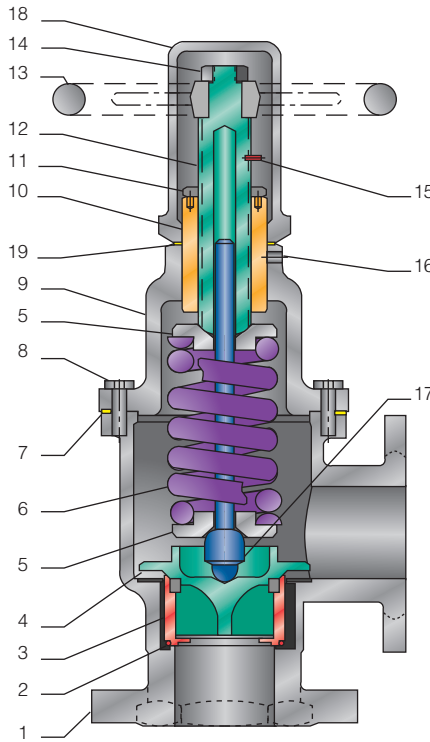

Model 228

Models 218 and 228 - Non-code

No.	Part Name	Materials
1	Body ¹	Iron, A126 Class A or B
2	O-ring	BUNA-N
3	Insert	2
4	Disc	2
5	Spring Step	3
6	Spring	Steel, Aluminum Coated
7	Bonnet Gasket	Fiber and Nitrile, Klinger C-4400 or C-4401
8	Hex Head Cap Screw ⁴	Steel, SAE Gr. ⁵
9	Bonnet	Iron, A126 Class A or B
10	Compression Screw Bushing	Brass, B16
11	Jam Nut	Brass, B16
12	Compression Screw	5
13	Handwheel	Iron, A126 Class A or B
14	Handwheel Locknut	Steel Plated, Commercial Gr.
15	Spring Pin	Steel, Commercial Gr.
16	Socket Set Screw	Steel, Commercial Gr.
17	Stem	3
	Compression Screw Locknut Wrench ⁶	Steel, A366
	Installation Instruction ⁶	Paper, Commercial Gr.

Model 228 Only

18	Cap ⁷	Iron, A126 Class A or B
19	Cap Gasket ⁷	Gasket, Klinger Silicone C-4400

Notes:

- Inlet and outlet flanges per ANSI B16.1 250#, inlet flange standard and 125# inlet flange optional. Outlet flange 125#.
- Disc (item 4) and insert (item 3) material Bronze, B-584 Alloy 84400 or B62, also available in SS, A743 Gr. CF-8, as a package option.
- Material CS with anti-corrosion coating, commercial Gr., Brass, B16 or SS, A582 TY 416.
- 6 bolts required for 3" and 4" sizes, and 8 bolts required for 6" size.
- Material Brass, B16 or Bronze, B584 casting (Model 218 only), B584 Alloy 84400 (Model 228 only).
- Not shown on assembly.
- Cap (item 18), Gasket (item 19) and Locknut (item 11) factory installed. Handwheel (item 13) shipped unassembled (Models 218 and 228).

KUNKLE SAFETY AND RELIEF PRODUCTS

MODELS 91, 218 AND 228

Specifications

Model 91¹

Model Number	Valve Size (in)	Connections ANSI Standard		Valve Dimensions			Min/Max Approx. Set Pressure (psig)		Approx. Weight (lb)
		Inlet	Outlet	A	B	C	Set Pressure (psig)	Weight (lb)	
091A-G	1 1/2 x 1 1/2	Female NPT	Female NPT	4 3/4	4 1/4	11 7/8	5/400	27	
091H-G	1 1/2 x 1 1/2	125# Flange	125# Flange	4 3/4	4 1/4	11 1/4	5/175	36	
091K-G	1 1/2 x 1 1/2	250# Flange	125# Flange	5	4 3/4	11 1/4	5/400	36	
091A-H	2 x 2	Female NPT	Female NPT	4 1/8	4 1/8	12 3/4	5/400	35	
091H-H	2 x 2	125# Flange	125# Flange	4 3/4	4 5/8	12 3/4	5/175	47	
091K-H	2 x 2	250# Flange	125# Flange	5	4 5/8	12 3/4	5/400	47	
091A-J	2 1/2 x 2 1/2	Female NPT	Female NPT	4 1/2	4 1/2	14 1/4	5/400	48	
091H-J	2 1/2 x 2 1/2	125# Flange	125# Flange	5 1/4	4 3/4	14 1/4	5/175	65	
091K-J	2 1/2 x 2 1/2	250# Flange	125# Flange	5 1/4	4 3/4	14 1/4	5/400	65	
091A-K	3 x 3	Female NPT	Female NPT	5 7/8	5 7/8	21	5/400	81	
091H-K	3 x 3	125# Flange	125# Flange	5 7/8	5 7/8	21 3/4	5/175	98	
091K-K	3 x 3	250# Flange	125# Flange	6 1/4	5 7/8	21 3/4	5/400	98	
091A-M	4 x 4	Female NPT	Female NPT	6 5/8	6 1/2	26	5/400	132	
091H-M	4 x 4	125# Flange	125# Flange	6 5/8	6 1/2	26	5/175	170	
091K-M	4 x 4	250# Flange	125# Flange	6 5/8	6 1/2	26	5/400	170	
091H-P	6 x 6	125# Flange	125# Flange	9 3/8	8 1/2	31	5/175	340	
091K-P	6 x 6	250# Flange	125# Flange	9 3/8	8 1/2	31	5/300	340	

Models 218 and 228¹

Model Number	Valve Size	Connections ANSI Standard		Valve Dimensions				Min/Max Set Pressure (psig)	Approx. Weight (lb)
		Inlet	Outlet	A	B	C (218)	C (228)		
2*8A-K ²	3 x 3	Female NPT	Female NPT	6 1/8	5 7/8	20 5/8	21 5/8	60/200	85
2*8H-K ²	3 x 3	125# Flange	125# Flange	6 1/8	5 7/8	20 5/8	21 5/8	60/175	110
2*8K-K ²	3 x 3	250# Flange	125# Flange	6 1/8	5 7/8	20 5/8	21 5/8	60/200	110
2*8A-M ²	4 x 4	Female NPT	Female NPT	6 5/8	6 1/2	25	26	60/200	143
2*8H-M ²	4 x 4	125# Flange	125# Flange	6 5/8	6 1/2	25	26	60/175	185
2*8K-M ²	4 x 4	250# Flange	125# Flange	6 5/8	6 1/2	25	26	60/200	185
2*8H-P ²	6 x 6	125# Flange	125# Flange	9 3/8	8 1/2	30	31	60/175	350
2*8K-P ²	6 x 6	250# Flange	125# Flange	9 3/8	8 1/2	30	31	60/200	350

Dimensions are for reference only.

Notes:

1. Temperature limits -20°F to 406°F.
2. Replace asterisk with desired model number. Data applicable to models 218, 228.

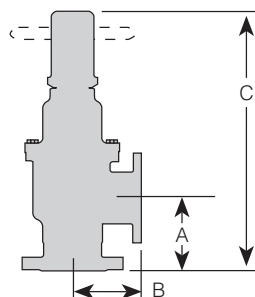

Model 91

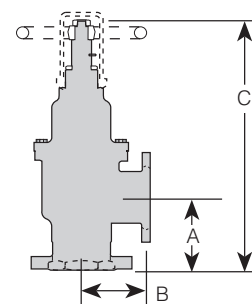

Models 218, 228

KUNKLE SAFETY AND RELIEF PRODUCTS

MODELS 91, 218 AND 228

Capacities

Liquid Overpressure Factors

To determine capacities at other than 25% overpressure/accumulation, multiply capacity shown by:

10% Acc. = 0.6

15% Acc. = 0.8

20% Acc. = 0.9

Models 218, 228 Capacities

UL/FM Size, in	Certified Capacities ¹ GPM
3 x 3	500
4 x 4	1000
6 x 6	2000

Note:

1. Rated at 100 psig set pressure and 25% accumulation 125 psig.

Non-code Liquid - 25% Accumulation (GPM) – Model 91 Only

Set Pressure (psig)	Inlet Size					
	1 1/2"	2"	2 1/2"	3"	4"	6"
5	31	56	87	125	224	447
10	44	79	123	177	316	632
20	63	111	174	250	447	894
30	77	136	213	307	548	1095
40	88	157	246	354	633	1265
50	99	176	275	396	707	1414
60	108	193	301	434	775	1549
70	117	208	325	468	837	1673
80	125	223	348	501	895	1789
90	133	236	369	531	949	1897
100	140	249	389	560	1000	2000
110	147	261	408	587	1049	2097
120	153	273	426	613	1096	2191
130	159	284	443	638	1140	2280
140	165	295	460	663	1183	2366
150	171	305	476	686	1225	2449
160	177	315	492	708	1265	2530
170	182	325	507	730	1304	2607
180	188	334	522	751	1342	2683
190	193	343	536	772	1379	2757
200	198	352	550	792	1414	2828
210	203	361	563	811	1449	2898
220	207	369	577	831	1483	2966
230	212	378	590	849	1517	3033
240	217	386	602	867	1549	3098
250	221	394	615	885	1581	3162
260	225	401	627	903	1613	3225
270	230	409	639	920	1643	3286
280	234	417	650	937	1673	3346
290	238	424	662	954	1703	3406
300	242	431	673	970	1732	3464
310	246	438	684	986	1761	—
320	250	445	695	1002	1789	—
330	254	452	706	1017	1817	—
340	258	459	717	1033	1844	—
350	261	466	727	1048	1871	—
360	265	472	738	1062	1898	—
370	269	479	748	1077	1924	—
380	272	485	758	1092	1950	—
390	276	492	768	1106	1975	—
400	280	498	777	1120	2000	—

KUNKLE SAFETY AND RELIEF PRODUCTS

MODELS 91, 218 AND 228

Model Number/Order Guide

Model Number Position

1	2	3	4	5	6	7	8	9	10	11	12	13	14	15
---	---	---	---	---	---	---	---	---	----	----	----	----	----	----

Example

0	9	1	K	—	M	0	1	A	M	S	0	4	0	0
---	---	---	---	---	---	---	---	---	---	---	---	---	---	---

Model

091
218
228

Connection Type

A - Female x Female NPT
H - 125# Flange x 125# Flange
K - 250# Flange x 125# Flange

Inlet Size

G - 1 1/2"
H - 2"
J - 2 1/2"
K - 3"
M - 4"
P - 6"

Variation

01 - Catalog standard
02 - SS seat and disc
03 - Model 91 w/handwheel (K, M and P inlet only)
03 - SST Seat, Disc and Stem (Model 218K-P only)
03 - Epoxy coated body and bonnet internal surfaces (all Models except Model 218K-P)
04 - Epoxy coated body and bonnet internal surfaces (Model 218K-P only)

Design Revision

Indicates non-interchangeable revision.
Current Design at Revision "A".

Valve Service

M - Liquid

Spring Material

C - Aluminum Coated, ASTM A231 Steel (G, H, J inlet sizes only)
S - Aluminum Coated, ASTM A229 Steel (K, M, P inlet sizes only)

Set Pressure

0005 - 5 psig
0400 - 400 psig



VALVES & CONTROLS

5500 WAYZATA BLVD # 800, MINNEAPOLIS, MN 55416 WWW.PENTAIR.COM/VALVES

KUNKLE FACILITY PHONE: 1-828-669-3700 • WWW.KUNKLEVALVE.COM

All Pentair trademarks and logos are owned by Pentair, Ltd. All other brand or product names trademarks or registered marks of their respective owners.

Because we are continuously improving our products and services, Pentair reserves the right to change specifications without prior notice. Pentair is an equal opportunity employer.